

# Several Polycyclic Valence Isomers of Dimethyl[14]annulene-1,8-dicarboxylate. Reactivity of a "Nonconjugated" Bis(bicyclo[1.1.0]butane)<sup>†</sup>

Manfred Christl,<sup>\*1a</sup> Silke Freund,<sup>1a</sup> Helmut Henneberger,<sup>1a</sup> Arno Kraft,<sup>1a</sup> Jürgen Hauck,<sup>1b</sup> and Hermann Irngartinger<sup>1b</sup>

Contribution from the Institut für Organische Chemie der Universität Würzburg, Am Hubland, D-8700 Würzburg, and Organisch-Chemisches Institut der Universität Heidelberg, Im Neuenheimer Feld 270, D-6900 Heidelberg 1, Federal Republic of Germany.

Received August 17, 1987

**Abstract:** Diels–Alder reaction of dimethyl 1,2,4,5-tetrazine-3,6-dicarboxylate (**5**) with benzvalene (**4**), norbornene, and norbornadiene afforded the azo compounds **7** and **8**. These are derivatives of 2,3-diazabicyclo[2.2.2]oct-2-ene as is azo compound **3**, which had been obtained previously from **5** and 2 equiv of benzvalene (**4**). The photochemical extrusion of nitrogen from **3**, **7**, and **8** has been studied. Whereas **7** and **8** on direct irradiation in benzene gave rise exclusively to the bicyclo[2.2.0]hexane derivatives **9** and **10**, respectively, from **3** in addition to the bicyclo[2.2.0]hexane **11**, the diolefin **12** was formed. Diolefin **12** has cis double bonds in the nine-membered ring and is fixed in a boat conformation in a manner so that the two bicyclobutane systems approach each other very closely. This geometry suggests the unusual ring opening of the intermediate 1,4-cyclohexanediyl diradical from a boat conformation, which arises by inversion of the primarily generated boat conformation. Sensitized photolysis of **3** as well as that of **12** produced the saturated isomer **13** of **11** and **12**. The proximity of the bicyclobutane systems in **12** causes unprecedented reactions leading to cage compounds. When **12** was heated at 90 °C, a rearrangement to the pentacyclic product **20** took place. Utilization of tetradeuterated substrate **12-d<sub>4</sub>** supported a pathway with two diradical intermediates. Behaving in a conventional manner, bicyclobutane **9** and bis(bicyclobutane) **11** took up 1 and 2 equiv of thiophenol most probably in a radical-chain addition to give the thioethers **28** and **29**, respectively. In contrast, bis(bicyclobutane) **12** was converted by 1 equiv of thiophenol into cage compound **30** in a process involving both the strained  $\sigma$  systems. Heating at 80 °C subjected **30** to a reversible Cope rearrangement, resulting in a 6:1 mixture of **31** and **30**. When it was treated with bromine, **12** was transformed to cage compound **38**. This addition is believed to proceed via a cationic intermediate. The structure of cage compound **20** was established by a single-crystal X-ray analysis of dialcohol **21** prepared from **20** and methylolithium.

Due to its large strain energy of 63.9<sup>2</sup> kcal/mol, bicyclo[1.1.0]butane and its derivatives can undergo a wide variety of reactions, which have been reviewed recently.<sup>3</sup> Additional types of transformations are possible if two bicyclobutane moieties are arranged next to each other ("conjugated") in one molecule.<sup>4,5</sup>

Herein we report the synthesis and several unexpected reactions of bis(bicyclo[1.1.0]butane) **12**, in which the bicyclobutane moieties are separated by four bonds, but in spite of that, they approach each other very closely. In addition, compound **12** is the first bicyclobutane derivative with a chain of six atoms bridging the endo positions. Until now, only bicyclobutanes with tethers consisting of up to four atoms were known.<sup>6,7</sup>

Our work was stimulated by a study of Sauer et al.,<sup>8</sup> who had obtained azo compound **1** from dimethyl 1,2,4,5-tetrazine-3,6-dicarboxylate (**5**) and norbornene. The photolysis of **1** in benzene

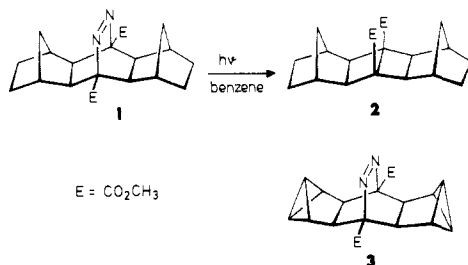

results in the extrusion of nitrogen and the formation of bicyclo[2.2.0]hexane derivative **2** in high yield.<sup>8</sup> Replacing norbornene by benzvalene (**4**), we have prepared azo compound **3** previously,<sup>9</sup> the configuration of which was established by single-crystal X-ray analysis.<sup>10</sup> In the present investigation, the photolysis of **3** was the key experiment, since direct irradiation produced the diolefinic bis(bicyclobutane) **12** in addition to bicyclo[2.2.0]hexane **11**.

## Results and Discussion

**Preparation of Azo Compounds 7 and 8.** The route to azo compound **3** passes dihydropyridazine **6**, which is generated rather fast from **4** and **5**. In contrast, the reaction between **4** and **6** proceeds considerably slower.<sup>9</sup> This gave us the possibility of adding olefins other than **4** to **6**. Thus, treatment of **6** with norbornene and norbornadiene resulted in the formation of azo compounds **7** and **8** isolated in 64 and 58% yields, respectively.

The configurations drawn for **7** and **8** seem reasonable in view of the known configuration of **3** and of the exo preference for cycloadditions to the double bonds of norbornene and norbornadiene.<sup>11</sup> Moreover, decoupling experiments in the <sup>1</sup>H NMR

(1) (a) Universität Würzburg. (b) Universität Heidelberg, X-ray analysis.  
(2) Wiberg, K. B. *Angew. Chem.* **1986**, *98*, 312; *Angew. Chem., Int. Ed. Engl.* **1986**, *25*, 312.

(3) (a) Christl, M. *Angew. Chem.* **1981**, *93*, 515; *Angew. Chem., Int. Ed. Engl.* **1981**, *20*, 529. (b) Hoz, S. In *The Chemistry of the Cyclopropyl Group*; Patai, S., Rappoport, Z., Eds.; Wiley-Interscience: Chichester, 1987; Part 2, p 1121.

(4) Szeimies, G.; Harnisch, J.; Stadler, K.-H. *Tetrahedron Lett.* **1978**, 243. Harnisch, J.; Szeimies, G. *Ibid.* **1978**, 247. Szeimies-Seebach, U.; Harnisch, J.; Szeimies, G.; Van Meerssche, M.; Germain, G.; Declercq, J.-P. *Angew. Chem.* **1978**, *90*, 904; *Angew. Chem., Int. Ed. Engl.* **1978**, *17*, 848. Römer, R.; Harnisch, J.; Röder, A.; Schöffner, A.; Szeimies, G.; Germain, G.; Arrieta, J. M. *Chem. Ber.* **1984**, *117*, 925.

(5) Paquette, L. A.; Browne, A. R.; Chamot, E. *Angew. Chem.* **1979**, *91*, 581; *Angew. Chem., Int. Ed. Engl.* **1979**, *18*, 546. Paquette, L. A.; Browne, A. R.; Chamot, E.; Blount, J. F. *J. Am. Chem. Soc.* **1980**, *102*, 643. Paquette, L. A.; Lau, C. J.; Browne, A. R.; O'Brien, M. E. *Ibid.* **1986**, *108*, 8111.

(6) (a) Christl, M.; Lang, R. *J. Am. Chem. Soc.* **1982**, *104*, 4494. (b) Christl, M.; Lang, R.; Herzog, C. *Tetrahedron Lett.* **1986**, *42*, 1585. (c) Christl, M.; Herzog, C.; Kemmer, P. *Chem. Ber.* **1986**, *119*, 3045.

(7) (a) Matsui, T.; Nakayama, M. *Bull. Chem. Soc. Jpn.* **1983**, *56*, 3531.

(8) Price, J. D.; Johnson, R. P. *Tetrahedron Lett.* **1986**, *27*, 4679.

(9) Dittmar, W.; Heinrichs, G.; Steigel, A.; Troll, T.; Sauer, J. *Tetrahedron Lett.* **1970**, 1623.

(10) Christl, M.; Lüddecke, H.-J.; Nagyrevi-Neppel, A.; Freitag, G. *Chem. Ber.* **1977**, *110*, 3745. The <sup>13</sup>C chemical shifts of **3** given in this paper contain an error: the value  $\delta$  39.9 should be replaced by 33.9.

(11) Irngartinger, H.; Lukas, K. L. *Angew. Chem.* **1979**, *91*, 750; *Angew. Chem., Int. Ed. Engl.* **1979**, *18*, 694.

<sup>†</sup> Dedicated to Professor John D. Roberts on the occasion of his 70th birthday.

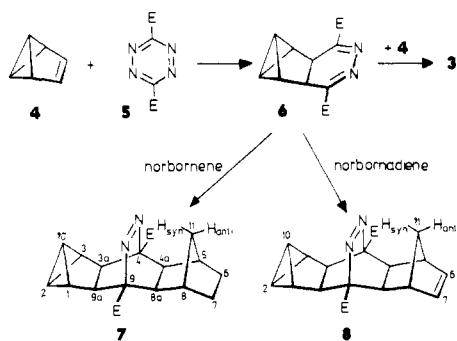

spectrum characterize **8** clearly as *exo,exo*-disubstituted norbornene. These decoupling experiments also permitted the specific assignment of both the 11-H signals. Different from the corresponding chemical shifts in norbornene ( $\delta_{\text{anti}}$  1.03,  $\delta_{\text{syn}}$  1.32<sup>12a</sup>), the proton above the CC double bond resonates at higher field (11- $H_{\text{anti}}$ ,  $\delta$  0.95). This has to be ascribed to the shielding anisotropy effect of the azo group, whereas 11- $H_{\text{syn}}$  ( $\delta$  1.29) is obviously deshielded by the proximate azo group, either due to its electronegativity or to the steric compression.<sup>12b</sup> Hence, in the case of 11- $H_{\text{syn}}$ , the shielding anisotropy effect is outweighed by a deshielding proximity influence.

**Photolysis of Azo Compounds 3, 7, and 8.** The photolysis of **7** in benzene or acetone followed the same course as that of **1**, with the bicyclo[2.2.0]hexane derivative **9** being the only product isolated in 53% yield. Analogously, the photolysis of **8** in benzene gave **10** isolated in 52% yield.

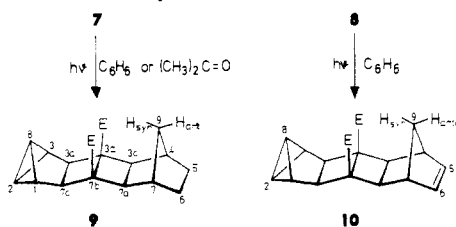

In contrast, the irradiation of azo compound **3** in benzene afforded a mixture of the octacyclic diester **11** and the hexacyclic

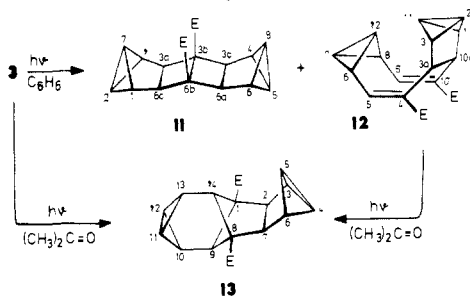

one **12** in the ratio 1.0:1.8. From the mixture, pure **12** was obtained in 36% yield by crystallization, whereas **11** could be isolated either by crystallization or distillation (20% yield). While **11** is formed like **2, 9**, and **10** by replacement of the azo bridge in the precursor by a  $\sigma$  bond with retention, diolefin **12** is the result of the rupture of a  $\sigma$  bond in addition to the elimination of nitrogen. The presence of the triplet quencher<sup>13</sup> piperylene in the reaction mixture did not change the result. Pure samples of **11** and **12** remained unchanged when they were resubmitted to irradiation in benzene. We also photolyzed **3** in  $\text{CD}_3\text{CN}$  to find out whether the ratio **11** to **12** is dependent on the temperature. And indeed, from 1.0:2.3 at 20 °C it decreased to 1.0:3.6 at -47 °C.

A completely different result was obtained when azo compound **3** was photolyzed in benzene in the presence of benzophenone or

in acetone. As the exclusive product, we isolated the octacyclic diester **13**. In the case of the irradiation in acetone, the yield was 40%. When the reaction was not carried to completion, the <sup>1</sup>H NMR spectrum of the crude product revealed the presence of diolefin **12** in addition to **13**. Consequently, we irradiated pure **12** in acetone and obtained **13** in 82%, whereas **11** proved to be stable under these conditions.

The structures of compounds **9–13** are supported by the NMR spectra, which indicate the symmetry of **9, 10, 12**, and **13** to be  $C_s$  and that of **11** to be  $C_{2v}$ . In particular, they show the presence of different bicyclobutane moieties in **12** and **13**. By comparison with the data of **11** and similar compounds,<sup>9,14</sup> one of these is identified to be part of a tricyclo[3.1.0.0<sup>2,6</sup>]hexane system since the central carbon atoms cause <sup>13</sup>C–H coupling constants across one bond of 217 (**12**) and 215 Hz (**13**). As has been pointed out previously,<sup>15,16</sup> bicyclobutane bridgeheads display smaller coupling constants if the endo positions are spanned by a chain of three or four carbon atoms. Thus, the values 210 Hz of **13** and 200 and 202 Hz of **12** are consistent with tethers of three and six carbon atoms, respectively. Also, the chemical shifts of C-6,8 ( $\delta$  47.96) and C-7, C-12 ( $\delta$  13.26, 17.53) of **12** are characteristically different from the corresponding values of typical tricyclo[3.1.0.0<sup>2,6</sup>]hexane systems<sup>9,14</sup> and rather similar to those of hydrooctalenes.<sup>16</sup> So far, the four carbon atoms spanning the endo positions of the bicyclobutane units of the latter compounds and octalene<sup>9a,b</sup> were the largest bridges. Except for the signals of C-7 and C-12 of **12**, all the absorptions of the bicyclobutane bridgeheads in the spectra of **12** and **13** could be assigned specifically on the basis of long-range coupling constants. These criteria have been developed previously by means of a series of tricyclo[3.1.0.0<sup>2,6</sup>]hexane derivatives.<sup>9,14</sup> Thus, other than 2-H of **12** and 4-H of **13**, 11-H of **12** and 5-H of **13** should give rise to the signals that display splittings in addition to those caused by vicinal interactions. The additional coupling is assigned to  $J_{3a,11} = 1.4$  Hz (**12**) and  $J_{2,5} = 1.2$  Hz (**13**) and should be transmitted by the favorable arrangement of the intervening bonds, which approximate a zigzag configuration.<sup>12c</sup> The same reasoning should apply for the characterization of the signals of 7-H and 12-H of **12**, where only 12-H should be capable of interacting with 5,9-H (1.2 Hz). Analogously, only one carbon each out of the pairs C-2, C-11 of **12** and C-4, C-5 of **13** is coupled across three bonds to 3a,10a-H of **12** (10 Hz) and 2,7-H of **13** (8 Hz), respectively. Since the antiperiplanar arrangement of the nuclei in question generally leads to larger vicinal coupling than the synclinal one, these carbon atoms should be C-11 of **12** and C-5 of **13**.

Structure **13** represents the sole configuration of this compound. However, there exist geometrical alternatives for **11** and **12** with the same symmetry, namely **11a** and **12a–c**, respectively, which

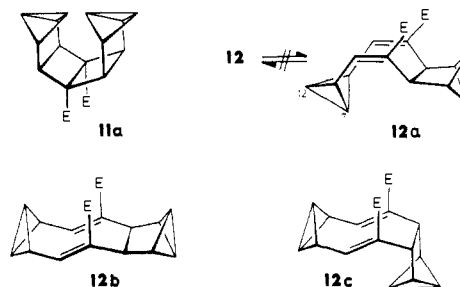

cannot be ruled out on the basis of the routine NMR spectra. In **11a** both the tricyclo[3.1.0.0<sup>2,6</sup>]hexane systems are annelated in the endo orientation at the bicyclo[2.2.0]hexane moiety. The sterically less congested *exo* annelation is shown in structure **11**. Structures **12b** and **12c** have two *trans* double bonds within the nine-membered ring, whereas **12** and **12a** with their *cis* double bonds are, in principle, interconvertible by a boat-to-boat inversion of the nine-membered ring. This process does not take place,

(11) Huisgen, R.; Ooms, P. H. J.; Mingin, M.; Allinger, N. L. *J. Am. Chem. Soc.* **1980**, *102*, 3951.

(12) Günther, H. *NMR-Spektroskopie*, 2nd ed.; Thieme: Stuttgart, FRG, 1983: (a) p 77, (b) p 89, (c) p 114, (d) p 110.

(13) Turro, N. J. *Modern Molecular Photochemistry*; Benjamin/Cummings: Menlo Park, CA, 1978.

(14) Christl, M.; Leininger, H.; Kemmer, P. *Chem. Ber.* **1984**, *117*, 2963.

(15) Christl, M. *Chem. Ber.* **1975**, *108*, 2781.

(16) Christl, M.; Herzog, C. *Chem. Ber.* **1986**, *119*, 3067.

Scheme I

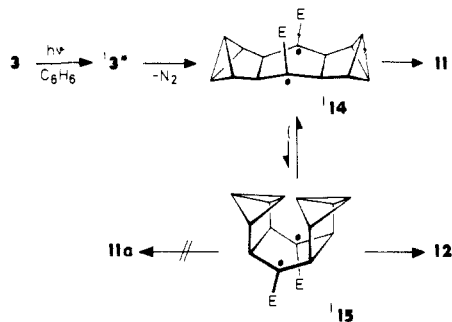

however, as can be judged from the fact that the <sup>1</sup>H NMR spectrum proved to be independent of the temperature.

We consider **11** and **12** rather than **11a** and **12a-c** as the correct structures on the basis of reactions of these compounds, i.e. the thermal rearrangement of **12** and the addition of thiophenol to **11** and **12** (see below). In the case of **12** this assumption is supported by the low-field resonances of 12-H ( $\delta$  2.47) and 11-H ( $\delta$  2.67) in the <sup>1</sup>H NMR spectrum as compared to those of 7-H ( $\delta$  1.79) and 2-H ( $\delta$  2.02), which are best rationalized in terms of the severe steric compression<sup>12b</sup> exerted on each other by 11-H and 12-H. Moreover, the proximity of the two bicyclobutane moieties in **12** is suggested by NOE measurements. Saturation of the resonance at  $\delta$  2.47 gave a strong enhancement at  $\delta$  2.67 and vice versa. Since the protons causing these signals do not belong to one bicyclobutane moiety, both bicyclobutane moieties have to be arranged next to each other.

Due to the strong nonbonded interaction between the two bicyclobutane moieties, **12** should be thermodynamically less stable than **12a**. Thus, the formation of **12** follows from kinetic control over the photochemical decomposition of azo compound **3**. A high barrier to the interconversion of **12** and **12a** is suggested by the most probable geometry of the transition state, in which C-3a,4,5,6 and C-8,9,10,10a would lie in one plane. The rigidity of the bicyclobutane (C-6,7,8,12) and the tricyclo[3.1.0.0<sup>2,6</sup>]hexane systems should prohibit other arrangements. In consequence, the transition state suffers from a considerable strain energy because of substantially increased bond angles in the nine-membered ring. Therefore, a barrier larger than that in the case of cyclooctatetraene (10.9, 14.5 kcal/mol<sup>17</sup>) is not unreasonable.

On the basis of the experimental results and the thorough photochemical studies of 2,3-diazabicyclo[2.2.2]octane and its derivatives,<sup>18,19</sup> we have to assume that the saturated product **11** is formed from azo compound **3** via the singlet excited state exclusively, whereas the saturated product **13** should arise from triplet states only. In contrast, diolefin **12** is generated from the singlet as well as from the triplet pathway, but in the latter case, it is transformed to the intramolecular [2 + 2] cycloadduct **13**.

Scheme I shows our proposal for the photolysis of **3** in benzene. The singlet excited state of **3** should eliminate nitrogen to produce the singlet diradical **14**, which may immediately collapse to give the saturated product **11**. The formation of diolefin **12** requires another intermediate, since the direct cleavage of the C-2-C-3 bond of the 1,4-cyclohexanediyl diradical would lead to the *trans*, *trans*-cyclononadiene derivative **12b**, which was not observed. Whether **12b** could be generated from **14** and undergo geometrical isomerization to **12** under irradiation appears to be unlikely in view of the absence of diolefinic products in the reactions of azo compounds **1**, **7**, and **8**. A more probable pathway to **12** involves a conformational process, namely the boat-to-boat inversion of 1,4-cyclohexanediyl diradical **14** to **15**, in which the fragmentation of a 1,4-butanediyl diradical unit should smoothly produce diolefin **12**. The reason why **15** would not collapse to

Scheme II

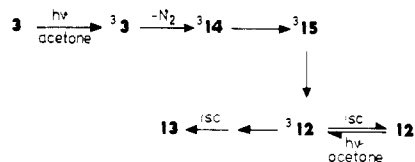

give **11a** is simply found in the severe nonbonded interaction between the two bicyclobutane moieties, which would increase on going to **11a** but is relieved somewhat in **12** due to the presence of two more sp<sup>2</sup>-hybridized carbon atoms.

The fact that the presence of piperylene does not change the **11** to **12** ratio (1.0:1.8 in benzene) excludes triplet excited states as precursors for the products. At first sight, one might expect some energy barrier to the interconversion of **14** and **15** and thus a higher portion of **11** on irradiation of **3** at low temperature. The latter is not the case, since in CD<sub>3</sub>CN at -47 °C the ratio **11**:**12** = 1.0:3.6 was decreased relative to that at 20 °C (1.0:2.3). Probably, the barrier to the equilibration **14**  $\rightleftharpoons$  **15** is low, and the product ratio is controlled by the activations necessary for bond making in **14** and bond breaking in **15**. Since **15** should be unfavorable relative to **14** due to the steric interactions between the two bicyclobutane systems, the bond rupture in **15** would require less activation than bond closure in **14**. This proposal finds support by the relief of strain energy to be expected on formation of **12** owing to the conversion of two sp<sup>3</sup>-hybridized carbon atoms into sp<sup>2</sup>-hybridized ones; hence, the distance between the bicyclobutane moieties gets larger. On the other hand, the bond making in **14** should increase the strain energy considerably due to five additional eclipsed interactions between the substituents at the exo face of the bicyclo[2.2.0]hexane nucleus in **11**.

The irradiation of azo compounds **1**, **7**, and **8** gives rise to bicyclo[2.2.0]hexane derivatives only. No diolefinic products

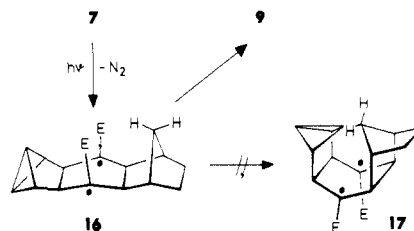

analogous to **12** have been found. Most probably, the reasons for this reside in the conformational equilibrium between the two 1,4-cyclohexanediyl boat forms. Representative for these cases, the formula of diradical **17** shows that a norbornane moiety enhances the steric compression considerably between the two ring systems annelated at the endo side of the 1,4-cyclohexanediyl diradical. Consequently, **17** may be destabilized much stronger relative to **16** as **15** is relative to **14** and, hence, the inversion of **16** to **17** could be too slow to compete with the ring closure to give **9**.

The pathway to the saturated product **13** on irradiation of azo compound **3** in the presence of triplet sensitizers (acetone, benzophenone) is shown in Scheme II. In the first stages, it differs from Scheme I by replacement of the singlet intermediates by the triplets **3**<sup>\*</sup>, **14**<sup>\*</sup>, and **15**<sup>\*</sup>. In harmony with a recent proposal to a mechanistic explanation of the results of 2,3-diazabicyclo[2.2.2]oct-2-ene photolyses,<sup>19</sup> the bond breaking to give **12** is much more strongly favored than on the singlet route. In fact, bicyclo[2.2.0]hexane derivative **11** was no longer observed. Due to the rapid bond breaking in **15**<sup>\*</sup>, diradical **14**<sup>\*</sup> does not live long enough to undergo intersystem crossing required prior to conversion into **11**. With the triplet state of **12**, i.e. **12**<sup>\*</sup>, the point of no return is reached, from which a reversible route leads to **12** and an irreversible one to **13**. The finding that even in acetone the irradiation of azo compound **7** affords only **9** and no diolefinic product is evidence against the occurrence of diradical **17**.

In one point, Schemes I and II are at variance with the mechanistic model for the ratio of bicyclo[2.2.0]hexane to 1,5-hexadiene products on 2,3-diazabicyclo[2.2.2]oct-2-ene photolyses

(17) Fray, G. I.; Saxton, R. G. *The Chemistry of Cyclooctatetraene and Its Derivatives*; Cambridge University: Cambridge, England, 1978.

(18) Engel, P. S. *Chem. Rev.* **1980**, *80*, 99.

(19) Engel, P. S.; Horsey, D. W.; Keys, D. E.; Nalepa, C. J.; Soltero, L. R. *J. Am. Chem. Soc.* **1983**, *105*, 7108.

**Table I.**  $^1\text{H}$  NMR Chemical Shifts ( $\delta$ ) and Coupling Constants (Hz)<sup>a</sup> of the Pentacyclic Compounds **20** and **21**

| compd                  | solvt                      | 1-H              | 1a-H              | 1b-H               | 1c-H             | 2-H             | 3-H              | 3a-H             | 4-H             | 6-H              | 6a-H              | 6b-H | 8-H  |
|------------------------|----------------------------|------------------|-------------------|--------------------|------------------|-----------------|------------------|------------------|-----------------|------------------|-------------------|------|------|
| <b>20</b> <sup>b</sup> | $\text{C}_6\text{D}_6$     | 2.53             | 2.02              | 2.71               | 2.89             | 6.07            | 5.74             | 2.98             | 4.38            | 7.13             | 2.83              | 1.73 | 7.40 |
| <b>21</b> <sup>c</sup> | $(\text{CD}_3)_2\text{SO}$ | 1.41             | 2.06              | 3.02               | 2.99             | 6.21            | 5.91             | 2.86             | 3.23            | 5.54             | 3.13              | 1.91 | 5.78 |
|                        |                            | $J_{1,1a} = 5.8$ | $J_{1a,1b} = 5.4$ | $J_{1b,6a} = 10.0$ | $J_{1c,2} = 1.1$ | $J_{2,3} = 2.8$ | $J_{3,3a} = 1.0$ | $J_{3a,4} = 7.4$ | $J_{4,6} = 1.2$ | $J_{6,6a} = 8.0$ | $J_{6a,6b} = 5.4$ |      |      |
|                        |                            | $J_{1,6b} = 5.8$ | $J_{1a,6b} = 5.4$ | $J_{1c,2} = 1.1$   | $J_{1c,3} = 0.8$ |                 |                  |                  |                 |                  |                   |      |      |
|                        |                            | $J_{1,8} = 0.9$  | $J_{1b,1c} = 9.4$ |                    |                  |                 |                  |                  |                 |                  |                   |      |      |

<sup>a</sup>The coupling constants given are those of **20**, from which those of **21** deviate at most by  $\pm 0.4$  Hz. <sup>b</sup> $\text{OCH}_3$ :  $\delta$  3.34, 3.40. <sup>c</sup> $\text{CH}_3$ :  $\delta$  1.13, 1.19, 1.22, 1.26. OH:  $\delta$  4.32, 4.35.

**Table II.**  $^{13}\text{C}$  NMR Chemical Shifts ( $\delta$ ) of the Pentacyclic Compounds **20** and **21**, One-Bond  $^{13}\text{C}$ -H Coupling Constants (Hz) of **20** (in Parentheses), and Deuterium Isotope Effects (ppm) on the  $^{13}\text{C}$  NMR Chemical Shifts of **20** As Determined from Mixtures of **20-d**<sub>4</sub> and **20**

| compd  | solvt                      | C-1            | C-1a               | C-1b               | C-1c               | C-2                 | C-3                 | C-3a               | C-4            | C-5                 | C-6                 | C-6a               | C-6b               | C-7                 | C-8                 |
|--|----------------------------|----------------|--------------------|--------------------|--------------------|---------------------|---------------------|--------------------|----------------|---------------------|---------------------|--------------------|--------------------|---------------------|---------------------|
| <b>20</b> <sup>a</sup>   | $\text{CDCl}_3$            | 22.79<br>(149) | 28.25<br>(181)     | 35.60<br>(134)     | 46.11<br>(133)     | 138.67<br>(170)     | 138.25<br>(170)     | 46.25<br>(136)     | 36.36<br>(128) | 135.40              | 144.96<br>(157)     | 34.44<br>(135)     | 24.30<br>(181)     | 136.21              | 142.01<br>(158)     |
| <b>21</b> <sup>b</sup>   | $(\text{CD}_3)_2\text{SO}$ | 23.32          | 27.28 <sup>c</sup> | 33.48 <sup>d</sup> | 45.72 <sup>e</sup> | 137.27 <sup>f</sup> | 138.81 <sup>f</sup> | 47.51 <sup>e</sup> | 37.22          | 148.47 <sup>g</sup> | 122.25 <sup>h</sup> | 34.61 <sup>d</sup> | 25.44 <sup>c</sup> | 152.61 <sup>g</sup> | 122.99 <sup>h</sup> |
| $\Delta\delta$ <b>20-d</b> <sub>4</sub> - <b>20</b> <sup>i</sup> |                            | -0.13          | -0.33              | -0.55              | -0.56              | -0.25               | -0.16               | -0.30              | 0.00           | 0.00                | +0.03               | -0.24              | -0.31              | 0.00                | 0.00                |

<sup>a</sup> $\text{CO}_2\text{CH}_3$ :  $\delta$  170.13, 168.46; 52.31, 52.18. <sup>b</sup> $\text{C}(\text{CH}_3)_2\text{OH}$ :  $\delta$  74.22, 72.13; 30.10, 30.03, 28.63 (double intensity). <sup>c-h</sup>The assignment of these resonances may be exchanged. <sup>i</sup>Resolution 0.01 ppm.

proposed by Engel et al.,<sup>19</sup> as are related results obtained from irradiation of the azo compounds prepared in analogy to **3** from 1,2,4,5-tetrazines and cycloolefins of small ring size.<sup>20</sup> In all these cases owing to two fused small rings, the 1,4-cyclohexanediyl diradical intermediates cannot adopt the chair conformation considered to be the origin of 1,5-hexadiene products.<sup>19</sup> On the other hand, their chair conformation would generate diolefins with trans double bonds<sup>21</sup> or products thereof, which have not been observed so far in the above cases. In an example with only one fused four-membered ring, a half-chair conformation of the diradical has been postulated to rationalize the formation of *cis*,*trans*-1,5-cyclooctadiene.<sup>22</sup> The reactions cited<sup>20</sup> and the conversion of **3** into **12** demonstrate that bisfused 1,4-cyclohexanediyl diradicals may give *cis*,*cis*-cycloalkadienes from a boat conformation accessible by inversion of the primary boat form. The latter one, e.g. **14**, is unable to produce a diolefin, since this would suffer from two trans double bonds in a rather small ring as a consequence of the configuration of the azo precursor having the fused rings arranged syn relative to the azo bridge.

Several reasons render the transformation of diolefin **12** to the saturated product **13** interesting, although intramolecular photochemical [2 + 2] cycloadditions of that kind are well-known.<sup>23</sup> Compound **12** is a derivative of 1,5-hexadiene and at the same time one of 1,6-heptadiene. In general,  $\alpha,\omega$ -dicarboxylic acid esters of the former diolefin afford bridged [2 + 2] cycloadducts<sup>24</sup> on sensitized irradiation, whereas those of the latter give rise to fused ones.<sup>24,25</sup> In particular, we have shown previously that the divinylbicyclobutane **18**, the structure and configuration of which

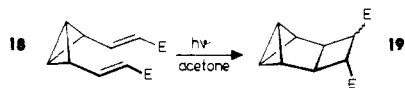

are contained in **12**, undergoes only the parallel cycloaddition on photolysis in acetone with formation of two diastereomeric tetracyclooctane derivatives **19**.<sup>26</sup> However, in **12** the 1,5-hexadiene moiety enforces the bridged reaction mode. On the other hand, one has to bear in mind that the parallel [2 + 2] cycloaddition may be unfavorable since the highly strained **11a** would be produced. In view of the nonconcerted course of these reactions, the

generation of the diradical intermediates of both the alternatives seems possible, but the precursor to **11a**, i.e. **15**, would decompose with strong preference into **12** rather than collapse to **11a**. On the basis of MO theory, Gleiter et al.<sup>27</sup> have recently presented a rationalization for the different intramolecular [2 + 2] cycloadditions of 1,5-hexadienes and 1,6-heptadienes on sensitized irradiation.

**Rearrangement of Bis(bicyclobutane) 12.** Bis(bicyclobutane) **12** proved to be rather labile. Even the measurement of the routine  $^{13}\text{C}$  NMR spectrum, during which **12** was exposed for about 0.5

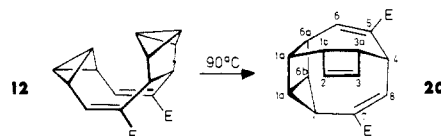

h to a temperature of about 40 °C due to broad-band decoupling, resulted in the appearance of an additional set of signals. The preparative experiment was conducted in benzene as solvent at 90 °C in a sealed tube and led to the isolation of triolefin **20** in 77% yield. A run in  $\text{C}_6\text{D}_6$  in a sealed NMR tube containing mesitylene as internal standard showed that the conversion of **12** into **20** proceeds almost quantitatively (94%).

The structure of **20** was elucidated on the basis of the NMR spectra (Tables I and II). From the  $^1\text{H}$  and the nondecoupled  $^{13}\text{C}$  NMR spectra, the presence of two acrylate units (6-H, 8-H:  $\delta$  7.13, 7.40), a cyclobutene unit (2-H, 3-H:  $\delta$  6.07, 5.74;  $J_{2,3} = 2.8$  Hz), a cyclopropane moiety (C-1, C-1a, C-6b:  $\delta$  22.79, 28.25, 24.30;  $J_{\text{C,H}} = 149, 181, 181$  Hz), and a doubly allylic CH group (4-H:  $\delta$  4.38) were evident as building blocks. The three-membered ring as constituent of a bicyclo[2.1.0]pentane system followed from the fact that two protons, having been characterized as occupying  $\alpha$ -positions relative to the cyclopropane by decoupling experiments, exhibit a mutual coupling of 10.0 Hz ( $J_{1b,6a}$ ) and should thus have a vicinal relationship. Finally, extensive decoupling experiments in the 400-MHz  $^1\text{H}$  NMR spectrum gave the information for the assembly of the building blocks.

The determination of a structure by spectroscopic methods is always indirect and lacks complete certainty. Since a structural relationship of **20** with the starting material **12** is not discernible

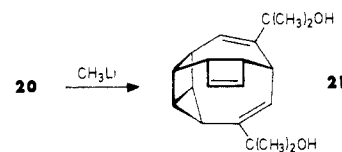

(27) Gleiter, R.; Sander, W. *Angew. Chem.* **1985**, *97*, 575; *Angew. Chem., Int. Ed. Engl.* **1985**, *24*, 566.

(20) Paquette, L. A.; Epstein, M. J. *J. Am. Chem. Soc.* **1973**, *95*, 6717. Martin, H.-D.; Hekman, M. *Tetrahedron Lett.* **1978**, 1183. Fühlhuber, H. D.; Gousetis, C.; Troll, T.; Sauer, J. *Tetrahedron Lett.* **1978**, 3903. Gousetis, C.; Sauer, J. *Tetrahedron Lett.* **1979**, 1295.

(21) Roth, W. R.; Martin, M. *Tetrahedron Lett.* **1967**, 3865.

(22) Martin, H.-D.; Heiser, B.; Kunze, M. *Angew. Chem.* **1978**, *90*, 735; *Angew. Chem., Int. Ed. Engl.* **1978**, *17*, 696.

(23) Srinivasan, R.; Carlough, K. H. *J. Am. Chem. Soc.* **1967**, *89*, 4932.

(24) Scheffer, J. R.; Wostradowski, R. A. *J. Org. Chem.* **1972**, *37*, 4317.

(25) Trautmann, W.; Musso, H. *Chem. Ber.* **1981**, *114*, 982.

(26) Leininger, H.; Christl, M.; Wendisch, D. *Chem. Ber.* **1983**, *116*, 681.

Scheme III

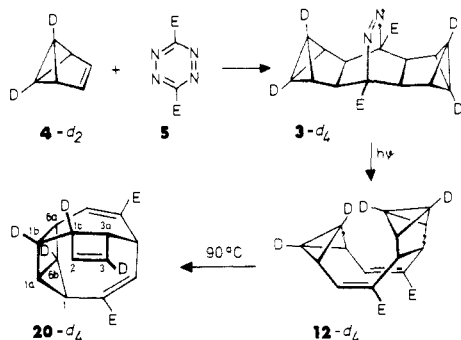

at first sight, we strived for a structural proof by means of an X-ray crystallographic analysis. However, single crystals of **20** of sufficient quality could not be obtained. By treating **20** with methyllithium, we reached the goal finally. The diol **21** was isolated in 76% yield and crystallized beautifully. The NMR spectra (Tables I and II) showed that the skeleton of **20** had not undergone any alteration during the derivatization of the ester groups. An X-ray crystallographic analysis (see below) removed doubts regarding the structures of **20** and **21** definitively.

To collect information on the mechanism of the transformation **12** → **20**, we thermolyzed tetradeuteriated bis(bicyclobutane) **12-d<sub>4</sub>** prepared from dideuteriobenzvalene (**4-d<sub>2</sub>**) and tetrazine **5** according to Scheme III. A single isotopomer, **20-d<sub>4</sub>**, was formed exclusively. The location of the deuterium labels in the positions 1b, 1c, and 6b was immediately obvious from the <sup>1</sup>H NMR spectrum. However, the determination of whether the fourth label was attached to C-2 or C-3 turned out to be difficult for two reasons: (i) In cyclobutenes vicinal and allylic coupling of the olefinic protons with the protons of the saturated C atoms, i.e.  $J_{1c,2}$  and  $J_{2,3a}$  as well as  $J_{1c,3}$  and  $J_{3,3a}$  in **20**, are hard to distinguish.<sup>28</sup> (ii) In the <sup>13</sup>C NMR spectrum the specific assignment of the signals to C-2 and C-3 is impossible due to a chemical shift difference of only 0.42 ppm. Consequently, the isotopomer of **20-d<sub>4</sub>** with a D atom at C-2 instead of C-3 was a realistic alternative a priori. We arrived at the decision in favor of **20-d<sub>4</sub>** on the basis of the deuterium isotope effects in the <sup>13</sup>C NMR spectrum (Table II), which were obtained from several mixtures of **20** and **20-d<sub>4</sub>** of different relative concentrations. Since the deuterium isotope effects on the <sup>13</sup>C chemical shifts of cyclobutene are known,<sup>29</sup> we calculated expected values for **20-d<sub>4</sub>** and its alternative starting from the chemical shifts of **20** and assuming the additive behavior of the two D atoms at the cyclobutene moiety. Allowance was made for the influence of the D atom at C-1b by using published values,<sup>30</sup> although this proved not to be critical regarding the assignment of C-2 and C-3. By comparison of the calculated and found values, the D atom at the olefinic part of the cyclobutene moiety has to be located at C-3; i.e. **20-d<sub>4</sub>** shows the correct distribution of the labels, and the alternative isotopomer with a D atom at C-2 is ruled out. This assignment was independently proved by NOE measurements in the <sup>1</sup>H NMR spectrum of **20**. Saturation of the resonance of 4-H and 8-H resulted in an enhanced absorption at δ 5.74 (3-H) and no effect at δ 6.07 (2-H), whereas saturation of the 1a-H signal gave an enhanced absorption at δ 6.07 (2-H) and no effect at δ 5.74 (3-H).

In both the four-membered rings of **20-d<sub>4</sub>** the labels are situated vis-à-vis, and furthermore, the four-membered rings are directly connected. We take these facts as evidence for the first step in the rearrangement of **12-d<sub>4</sub>** (Scheme IV). Thus, the central bonds of both bicyclobutane moieties should be broken with concomitant formation of a bond between these units to give diradical **22**. Usually, the formation of *one* CC single bond on the account of *two* is energetically not feasible. But in the case of the process

Scheme IV

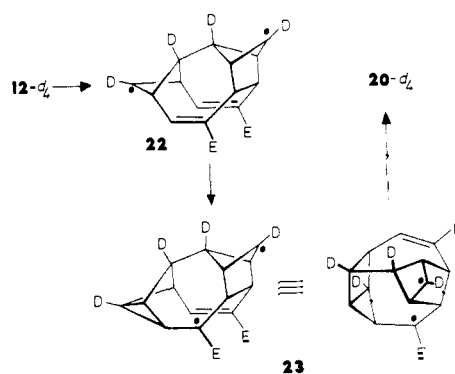

**12-d<sub>4</sub>** → **22**, twice the difference of the strain energies of bicyclobutane (63.9 kcal/mol)<sup>2</sup> and cyclobutane (26.5 kcal/mol)<sup>2</sup> mitigates the energetic deficit. Consequently, this step should only be slightly endothermic, i.e. by about 10 kcal/mol or less. Of course, this type of reaction has its origin in the close proximity of the two bicyclobutane moieties in **12** and would not be possible in the configurational alternatives **12a-c**. From diradical **22**, two simple steps well-known in radical chemistry lead to **20-d<sub>4</sub>**. The first one is a homoallyl-cyclopropylcarbinyl radical rearrangement to give **23**, which turns out to be a derivative of the tetramethylene diradical with a fixed antiperiplanar conformation. Its fragmentation represents the second step giving rise to the π bonds in the cyclobutene unit and the reorganized acrylate group.

**Addition of Thiophenol to the Bicyclobutane Derivatives 9, 11, and 12.** Szeimies et al.<sup>31</sup> have characterized the addition of thiophenol to the central bond of a bicyclobutane moiety as a radical-chain reaction proceeding exclusively with inversion of the configuration of the carbon atom attacked by the thiyl radical. Several examples of our work demonstrate the synthetic potential of this reaction for the preparation of cyclobutenes from bicyclobutanes.<sup>14,32</sup> The fact that tricyclo[4.1.0.0<sup>2,7</sup>]heptane (**26**)

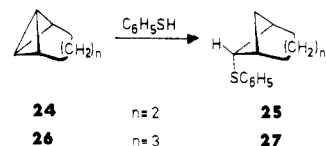

reacts much faster than tricyclo[3.1.0.0<sup>2,6</sup>]hexane (**24**) discloses a strong dependence of the rate, with which the thiyl radical adds to the strained σ bond, on the flap angle of the bicyclobutane system.<sup>31c</sup>

Thus with respect to bis(bicyclobutane) **12**, two very interesting questions arose: (i) Which one of the two strained σ systems would react faster? Due to the larger flap angle, the bicyclobutane unit with the six-membered bridge should be favored by the thiyl radical over the tricyclo[3.1.0.0<sup>2,6</sup>]hexane moiety, but the conjugation with the acrylate functionalities could deactivate the former, since thiyl radicals are electrophilic.<sup>31c,33</sup> (ii) Would **12** accept two thiol molecules, one at each bicyclobutane system, or only one because of the transannular interaction between the two strained σ systems?

As model substrates the mono(bicyclobutane) **9** and the bis(bicyclobutane) **11** were treated with thiophenol in benzene. In close analogy to **24**, where best results as to yield and purity of **25** were obtained with photochemical initiation,<sup>32a</sup> irradiation afforded the expected products, i.e. the 1:1 adduct **28** and the 1:2 adduct **29**, in 29 and 90% yields, respectively. As compared to

(31) (a) Szeimies, G.; Schlosser, A.; Philipp, F.; Dietz, P.; Mickler, W. *Chem. Ber.* **1978**, *111*, 1922. (b) Dietz, P.; Szeimies, G. *Chem. Ber.* **1980**, *113*, 398. (c) Schlosser, A.; Philipp, F.; Mickler, W.; Szeimies, G.; Martin, H.-D. *Chem. Ber.* **1980**, *113*, 1053.

(32) (a) Herbert, R.; Christl, M. *Chem. Ber.* **1979**, *112*, 2012. (b) Leininger, H.; Lanzendörfer, F.; Christl, M. *Chem. Ber.* **1983**, *116*, 669. (c) Herzog, C.; Lang, R.; Brückner, D.; Kemmer, P.; Christl, M. *Chem. Ber.* **1986**, *119*, 3027.

(33) Walling, C.; Seymour, D.; Wolfstirn, K. B. *J. Am. Chem. Soc.* **1948**, *70*, 2559.

(28) Cf. the coupling constants of 2-oxabicyclo[3.2.0]hepta-3,6-diene.<sup>14</sup>

(29) Hansen, P. E.; Led, J. J. *Org. Magn. Reson.* **1981**, *15*, 288.

(30) Wesener, J. R.; Moskau, D.; Günther, H. *J. Am. Chem. Soc.* **1985**, *107*, 7307.

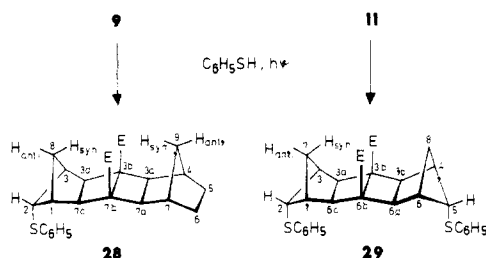

**11**, bis(bicyclobutane) **12** behaved differently. The reaction

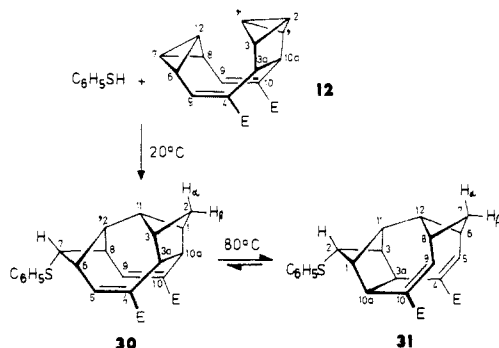

proceeded smoothly at room temperature, as that of tricycloheptane **26** does,<sup>31a</sup> requiring no initiation in addition to that by aerial oxygen, and 1:1 adduct **30**, in which the central bond of both bicyclobutane entities has been broken, was isolated in 94% yield. That indeed **30** was formed and not the alternative thioether **31** could be demonstrated by heating the primary product. At 80 °C in benzene as solvent a clean Cope rearrangement took place, leading to an equilibrium mixture with **30** and **31** present in the ratio 1:6. Pure **31** could be isolated by chromatography.

The structures of **28–31** were derived from the NMR spectra, which indicate  $C_s$  symmetry for **28**, **30**, and **31** and  $C_{2v}$  for **29**. On the basis of previous studies,<sup>31,32</sup> in particular on phenylthio-substituted tricyclo[3.1.0.0<sup>2,6</sup>]hexanes annelated to small rings,<sup>32a,34</sup> the phenylthio groups in **28–31** occupy a pseudoequatorial position of the respective cyclobutane ring in each case. The deciding criterion is provided by the magnitude of the coupling constant of the proton on the carbon bearing the sulfur atom with the neighboring bridgehead protons. This interaction would certainly be small if resolved at all in the case of a pseudoequatorial arrangement of the proton in question.<sup>31b,35</sup> However, it amounts to 2.0 Hz in **28** and **29** and 2.5 Hz in the product obtained by the Cope rearrangement. The values are in accord with the corresponding coupling observed in the parent bicyclohexyl phenyl thioether (**25**) (2.5 Hz).<sup>36</sup> In the spectrum of the primary product formed from **12** and thiophenol, this coupling constant was determined to be 7.7 Hz, the increased magnitude being in line with  $J_{1,6}$  in bicycloheptyl phenyl thioether (**27**) (6 Hz<sup>31a</sup>) and related norpinenes (5.1–5.4 Hz<sup>32c</sup>). Thus, it is justified to assign structure **30** with a chain of six carbon atoms bridging the phenylthio-substituted cyclobutane unit to the primary adduct of thiophenol to **12** and structure **31** with a tricyclohexyl phenyl thioether moiety to the rearranged product. The coupling constants of the methylene protons in **30** and **31** support this assignment:  $J_{1,2\alpha} = 2.8$  Hz and  $J_{1,2\beta}$  not resolved in **30**;  $J_{6,7\alpha} = 8.4$ ,  $J_{6,7\beta} = 1.7$  Hz in **31**. The considerable magnitude of  $J_{6,7\beta}$  has precedent in corresponding interactions in bicyclo[4.1.1]octane and its derivatives,<sup>6b,37</sup> where a four-membered tether spans the cyclobutane ring.

Considering the mechanism of the formation of **30**, we believe that the phenylthiyl radical attacks **12** at the sterically least

hindered side of the bicyclobutane system with the larger bridge, i.e. at C-7. For the process making the transannular bond C-11–C-12 in **30**, two alternatives have been discussed: (i) The cyclobutyl radical **32** could be an intermediate, which underwent

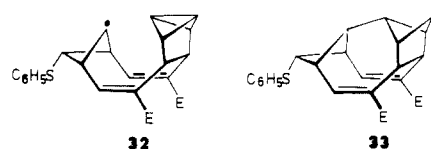

the transannular addition to the still present bicyclobutane moiety to produce cyclobutyl radical **33** in a second step. (ii) Radical **33** could be formed in one step from **12** and the phenylthiyl radical, with the second bicyclobutane system assisting the attack at the first one. At present, we have no results that bear on this question.

Clearly, the transannular reaction giving rise to **30** rules out **12a–c** as viable structural alternatives for **12**. Due to the large distance between the bicyclobutane systems, an interaction between them cannot be maintained. The conceivable route to radical **32** via addition of the thiyl radical at C-7 of conformer **12a** of **12** and subsequent boat-to-boat inversion of the nine-membered ring is unlikely in view of the fact that in general the radical attack takes place at the sterically least hindered side.<sup>31,32</sup> Thus, one would have to expect the reaction at C-12 of **12a**, which precluded a transannular bond making with or without inversion of the nine-membered ring. Also, configuration **11a** must be rejected as alternative for **11**. Different from what has been observed (production of **29**), it would certainly take up only one thiophenol molecule in a process accompanied by transannular bond formation owing to the close proximity of the bicyclobutane systems.

**Addition of Bromine to Bis(bicyclobutane) 12.** The known additions of bromine and iodine to bicyclobutane and its derivatives have been quoted in connection with our syntheses of octalenes<sup>6b</sup> and norpinenes.<sup>32c</sup> It appears that most of these reactions are radical-chain processes giving rise to 1,3-dihalocyclobutanes, e.g. tetrabromonorpinene (**35**) from dibromohomobenzvalene (**34**).<sup>32c</sup>

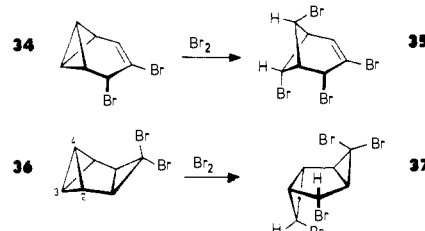

Interestingly, dibromotetracycloheptane **36**, an isomer of **34**, is converted by bromine into the cyclopropylcarbinyl derivative **37**.<sup>32c</sup> Here, the attachment of the bromine atoms takes place at the sterically least hindered side under rupture of a lateral bond of the bicyclobutane system with double retention.

We take these facts as evidence for an ionic pathway, in which a bromine cation is transferred to C-3 of **36** and a cationic center develops at C-2. The latter combines with the bromide counterion to yield **37**, with the stereochemistry of this step probably being a consequence of the generation of the intermediate as contact ion pair.

Treatment of bis(bicyclobutane) **12** with elemental bromine in tetrachloromethane afforded a 1:1 adduct in 39% yield. On

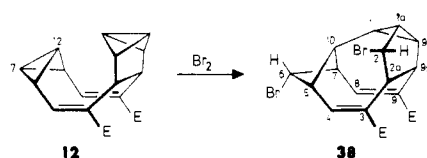

the basis of the NMR spectra, we propose the structure to be **38**. As in the case of the thioether **30**, the acrylate units are retained, but they are different. Hence, the symmetry of **12** is lost in this reaction. Nevertheless, 6 out of the 12 proton signals closely resemble 6 multiplets in the spectrum of **30**. We assign these signals to 4-, 5-, 6-, 7-, 8-, and 10-H. In particular, the coupling

(34) Christl, M.; Herbert, R. *Chem. Ber.* **1979**, *112*, 2022.

(35) Wiberg, K. B.; Lowry, B. R.; Nist, B. J. *J. Am. Chem. Soc.* **1962**, *84*, 1594. Wiberg, K. B.; Hess, B. A., Jr. *J. Org. Chem.* **1966**, *31*, 2250.

(36) In ref 31a, 32a this coupling constant of **25** was not specified due to long-range coupling and second-order effects. We have obtained these data now by means of decoupling experiments in the 200-MHz spectrum:  $J_{1,5} = 2.5$ ,  $J_{2,exo,5} = 1.2$ ,  $J_{2,endo,6anti} = 2.5$  Hz.

(37) Christl, M.; Herzog, C.; Nusser, R. *Chem. Ber.* **1986**, *119*, 3059.

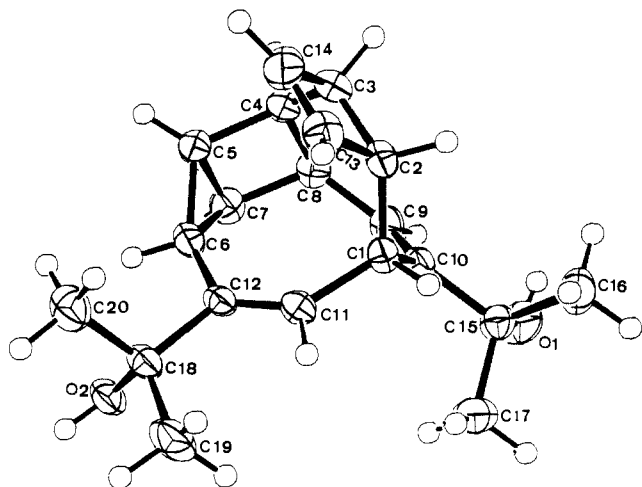
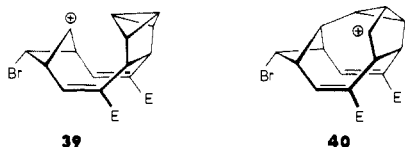

Figure 1. ORTEP drawing of **21**. The numbering does not correspond to the systematic name.

constants  $J_{5,6} = J_{6,7} = 7.4$  Hz and  $J_{5,10} = J_{7,10} = 7.7$  Hz as well as the fine structure of the multiplets caused by 4-, 5-, 7-, and 8-H match the corresponding parameters of **30** convincingly. On the other hand, the proton-coupled  $^{13}\text{C}$  NMR spectrum reveals the presence of a cyclopropane ring by three resonances ( $\delta$  21.05, 27.24, 32.54) with  $^1J_{\text{C,H}} = 156, 174,$  and  $172$  Hz, respectively. The configuration of C-2 with the bromine atom at the  $\alpha$  (endo) side follows from the vicinal coupling constants of 2-H ( $J_{1a,2} = 5.2, J_{2,2a} = 11.0$  Hz), which indicate synperiplanar relationships. If the bromine atom would be attached  $\beta$  (exo) oriented, the respective vicinal couplings would be much smaller due to dihedral angles of about  $120^\circ$ .<sup>12d</sup>

Since the addition of bromine to **12** produces the cyclopropylcarbiny derivative **38**, we consider the pathway to involve



not radicals but ionic intermediates. Obviously, the direct precursor to **38** is cation **40**, which has to take up the bromide ion on the endo face of the five-membered ring. This indicates a contact ion pair having the bromide ion adjacent to the site where the bromine cation has been bound. Cation **40** could be formed from cation **39** in a process typical for the attack of Brønsted or Lewis acids at the bicyclobutane system.<sup>3,32,38</sup> However, the generation of **39** from **12** appears to be unlikely in view of only very few examples, where a cyclobutane derivative is obtained from a bridged bicyclobutane system and a cationic electrophile.<sup>39a</sup> The overwhelming majority gives cyclopropylcarbiny derivatives. Thus, we suspect the transfer of a bromine cation to C-7 of **12** specifically to the backside of the C-7-C-12 bond under transannular assistance by the second bicyclobutane moiety. This process should immediately lead to cation **40** as the single intermediate. At present, we cannot offer a satisfactory explanation why thiophenol reacts with **12** in a radical-chain reaction, whereas bromine prefers an ionic pathway.<sup>39b</sup>

**X-ray Structure Determination of the Cage Compound 21** (Figure 1). In the molecular structure of cage compound **21** the partial structure of a bicyclo[2.1.0]pentane (C-4 to C-8) is in-

cluded. The bond distance between the bridgehead carbon atoms C-5-C-7 is 1.538 Å. This length compares well with the average value of 1.532 Å<sup>40</sup> found in several X-ray structure determinations of bicyclo[2.1.0]pentane derivatives. As in the bicyclo[1.1.0]butane system the central bond C-5-C-7 of **21** should be dependent on the dihedral angle between the three- and four-membered rings.<sup>10,41</sup> Since this angle of  $121.8^\circ$  in **21** is larger than the corresponding angle of  $112.4^\circ$  in other bicyclo[2.1.0]pentane derivatives<sup>40</sup> produced by the rigid polycyclic system of **21**, we expect a longer C-5-C-7 distance. On the other hand, these bonds are dependent on substituent effects.<sup>40</sup> The vinyl group C-11-C-12 has a cis-bisected orientation relative to the three-membered ring C-5-C-6-C-7. It deviates only by  $5^\circ$  from the optimal orientation. By interaction of the vinyl group with the three-membered ring, the distal bond, which is the bridging bond C-5-C-7, should be shortened. Therefore, the steric and substituent influences on this bond are counteracting. Consequently this bond length and the remaining bond distances of the bicyclo[2.1.0]pentane moiety of **21** have the same order of magnitude as the corresponding distances in analogous compounds.<sup>40</sup>

The cyclobutane ring (C-2-C-3-C-13-C-14) is planar ( $\pm 0.01$  Å). The particularly long C-2-C-3 distance of 1.566 Å is typical for this ring system.<sup>42</sup> The rigid cage system forces large bond angles ( $133.2^\circ, 130.1^\circ$ ) at the double bond C-11-C-12.

### Conclusion

Readily accessible from benzvalene (**4**) and tetrazine **5**, azo compound **3**, a derivative of diazabicyclo[2.2.2]oct-2-ene, loses nitrogen on photolysis. However, the direct irradiation in benzene or acetonitrile affords the expected octacyclic bis(bicyclobutane) **11** only as the minor product of a mixture, in which the hexacyclic and, thus, diolefinic bis(bicyclobutane) **12** dominates. Regarding the formation of **12**, we propose as the most likely mechanism the unusual ring opening of the respective 1,4-cyclohexanediyl diradical from a boat conformation, which arises by inversion of the boat conformation generated primarily by extrusion of nitrogen from excited **3**. The third and also octacyclic bis(bicyclobutane) **13** results from the sensitized photolysis of **3** or the diolefinic bis(bicyclobutane) **12**. The photolysis products **11-13** are valence isomers of dimethyl [14]annulene-1,8-dicarboxylate.

The chemistry of diolefin **12** is even more interesting than the photolysis of azo compound **3**. This stems from the proximity of the two bicyclobutane systems. They are predetermined for transannular processes due to overlap of the backlobes of the orbitals forming the central bicyclobutane bonds. Thus, in a unimolecular rearrangement most likely involving diradical intermediates, slight heating transforms **12** to cage compound **20**, another valence isomer of dimethyl [14]annulene-1,8-dicarboxylate. The radical-chain addition of thiophenol converts **12** into cage compound **30**. The third cage compound **38** is formed on treatment of **12** with bromine. This addition is believed to proceed via a cationic intermediate. These three reactions, which are of different types, lead to three types of unprecedented cage products. On the contrary, bis(bicyclobutane) **11** behaves conventionally in that it takes up two molecules of thiophenol. The large distance between the two bicyclobutane systems precludes a transannular interaction, which can also be assumed for bis(bicyclobutane) **13**. Addition reactions of azo compound **3**, which do involve transannular steps, with the azo bridge playing an active role, will be described elsewhere.<sup>43</sup> The initial steps of these processes are the same as those with the Diels-Alder adducts of benzvalene to cyclopentadiene derivatives. Two examples have been mentioned briefly.<sup>3a</sup>

(38) Wiberg, K. B.; Szeimies, G. *J. Am. Chem. Soc.* **1970**, *92*, 571.

(39) (a) Müller, E. *Chem. Ber.* **1975**, *108*, 1401. Cf. also: Hoz, S.; Livneh, M.; Cohen, D. *J. Org. Chem.* **1986**, *51*, 4537. (b) A reviewer suggested that a recent paper (Hoz, S.; Livneh, M.; Cohen, D.; *J. Am. Chem. Soc.* **1987**, *109*, 5149) might provide an explanation for the different modes of the reactions of thiophenol and bromine with **12**. This may well be so. Accordingly, bromine would initially accept an electron from the C-7-C-12 bond of **12** to form a radical cation, which would combine with a bromine atom (from  $\text{Br}_2 \rightarrow \text{Br}^- + \text{Br}^\cdot$ ) to give the intermediate **40**.

(40) Allen, F. H. *Acta Crystallogr., Sect. B: Struct. Sci.* **1984**, *B40*, 306.

(41) Paddon-Row, M. N.; Houk, K. N.; Dowd, P.; Garner, P.; Schappert, R. *Tetrahedron Lett.* **1981**, *22*, 4799. Eisenstein, M.; Hirshfeld, F. L. *Acta Crystallogr. Sect. B: Struct. Sci.* **1983**, *B39*, 61. Gassman, P. G.; Greenlee, M. L.; Dixon, D. A.; Richtsmeier, S.; Gougoutas, J. Z. *J. Am. Chem. Soc.* **1983**, *105*, 5865.

(42) Allen, F. H. *Acta Crystallogr., Sect. B: Struct. Sci.* **1984**, *B40*, 64.

(43) Freund, S.; Henneberger, H.; Christl, M., to be submitted for publication. Freund, S. Dissertation, Universität Würzburg, 1983. Henneberger, H. Dissertation, Universität Würzburg, 1987.

The astonishing reactivity of **12** raises expectations with regard to transannular interactions in molecules containing two (or more) bicyclobutane moieties in close proximity. Such compounds will certainly be useful for the preparation of novel polycyclic ring systems. Consequently, we are actively pursuing the synthesis of bis(bicyclobutanes).

### Experimental Section

**Dimethyl (1 $\alpha$ ,2 $\alpha$ ,3 $\alpha$ ,3 $\beta$ ,4 $\alpha$ ,4 $\beta$ ,5 $\alpha$ ,8 $\alpha$ ,8 $\beta$ ,9 $\alpha$ ,9 $\beta$ )-Decahydro-4,9-azo-5,8-methano-1,2,3-metheno-1H-benzf[*l*]indene-4,9-dicarboxylate (7).** Within 10 min a solution of benzvalene (**4**)<sup>44</sup> (5.12 mmol) in ether (15 mL) was added to tetrazine **5**<sup>45</sup> (1.00 g, 5.05 mmol) under nitrogen at 20 °C. Stirring was continued until the suspension of the red **5** had disappeared and a suspension of the yellow dihydropyridazine **6** had replaced it with evolution of nitrogen (15 min). After addition of norbornene (2.85 g, 30.3 mmol) in several portions, the mixture was stirred at 20 °C for 4 h, during which time the precipitate turned off-white. It was collected by filtration, washed with ether, and recrystallized from acetone to give 1.10 g (64%) of colorless azo compound **7**, mp 185–187 °C.

**Dimethyl (1 $\alpha$ ,2 $\alpha$ ,3 $\alpha$ ,3 $\beta$ ,4 $\alpha$ ,4 $\beta$ ,5 $\alpha$ ,8 $\alpha$ ,8 $\beta$ ,9 $\alpha$ ,9 $\beta$ )-2,3,3a,4a,5,8,8a,9a-Octahydro-4,9-azo-5,8-methano-1,2,3-metheno-1H-benzf[*l*]indene-4,9-dicarboxylate (8).** According to the procedure described above for **7** with norbornadiene instead of norbornene, azo compound **8** was obtained (58%) as a colorless solid, mp 178–179 °C (from acetone).

**Dimethyl (1 $\alpha$ ,2 $\alpha$ ,3 $\alpha$ ,3 $\beta$ ,3 $\beta$ ,4 $\alpha$ ,7 $\alpha$ ,7 $\beta$ ,7 $\beta$ ,7 $\beta$ )-Decahydro-4,7-methano-1,2,3-metheno-1H-cyclopenta[3',4']cyclobuta[1',2':3,4]-cyclobuta[1,2]benzene-3b,7b-dicarboxylate (9).** A solution of azo compound **7** (540 mg, 1.58 mmol) in benzene (200 mL) was deoxygenated with a gentle stream of nitrogen for 15 min. The mixture was irradiated with a high-pressure mercury vapor lamp (Hanau TQ 718, 700 W) through Pyrex glass for 2 h at ambient temperature. The solvent was removed in vacuo, and the remaining yellow oil crystallized on treatment with ether. After dissolution in ether and precipitation with hexane, **9** was isolated (267 mg, 53%) as a colorless solid, mp 89–90 °C. Photolysis of **7** in acetone as solvent also gave only **9**.

**Dimethyl (1 $\alpha$ ,2 $\alpha$ ,3 $\alpha$ ,3 $\beta$ ,3 $\beta$ ,4 $\alpha$ ,7 $\alpha$ ,7 $\beta$ ,7 $\beta$ ,7 $\beta$ )-2,3,3a,3c,4,7,7a,7c-Octahydro-4,7-methano-1,2,3-metheno-1H-cyclopenta[3',4']cyclobuta[1',2':3,4]cyclobuta[1,2]benzene-3b,7b-dicarboxylate (10).** Azo compound **8** was irradiated as described above for azo compound **7**. In benzene as solvent, **10** (52%) was obtained as a colorless solid, mp 69–72 °C (from chloroform/hexane).

**Dimethyl (1 $\alpha$ ,2 $\alpha$ ,3 $\alpha$ ,3 $\beta$ ,3 $\beta$ ,4 $\alpha$ ,5 $\alpha$ ,6 $\alpha$ ,6 $\beta$ ,6 $\beta$ ,6 $\beta$ )-2,3,3a,4,5,6,6a,6c-Octahydro-1,2,3,4,5,6-dimethenocyclopenta[3',4']cyclobuta[1',2':3,4]cyclobuta[1,2]cyclopentene-3b,6b(1H,3cH)-dicarboxylate (11) and Dimethyl 1,2,3,3a,6,7,8,10a-Octahydro-1,2,3:6,7,8-dimethenocyclopentacyclononene-4,10-dicarboxylate (12).** A solution of azo compound **3** (5.00 g, 15.3 mmol) in benzene (500 mL) was irradiated as described above for azo compound **7**. After evaporation of benzene in vacuo, a yellow oil remained, from which, on treatment with ether, colorless crystals of **12** (1.65 g, 36%), mp 78–80 °C, were obtained in several crops. The isolation of **11** from the mother liquor was achieved by concentration in vacuo, after which crystallization occurred sometimes (900 mg, 20%). Otherwise, the liquid residue was distilled at 150–155 °C (bath) (0.001 Torr) to give **11** as slightly yellow oil, which solidified on treatment with ether. The colorless crystals of **11** were purified by dissolution in ether and precipitation with hexane, mp 63–65 °C. The <sup>1</sup>H NMR spectrum of the crude product indicated the ratio **11**:**12** = 1.0:1.8.

**11:** IR (KBr, cm<sup>-1</sup>) 2945, 1745, 1705, 1443, 1330, 1305, 1258, 1125, 1105, 765; MS *m/z* (relative intensity) 298 (1%, M<sup>+</sup>) 207 (42), 180 (27), 179 (100), 178 (76), 165 (35), 152 (27), 115 (39), 104 (20), 103 (34), 91 (31), 78 (29), 77 (28), 59 (40); <sup>1</sup>H NMR (CDCl<sub>3</sub>)  $\delta$  1.95 (dt, *J*<sub>1,2</sub> = 1.4, *J*<sub>2,7</sub> = 8.8 Hz, 2-H), 2.00 (dtt, *J*<sub>1,7</sub> = 1.8, *J*<sub>3a,7</sub> = 0.8 Hz, 7-H), 2.12 (br s, 1,3-H), 2.45 (br s, 3a,6c-H), 3.69 (s, OCH<sub>3</sub>); <sup>13</sup>C NMR (CDCl<sub>3</sub>)  $\delta$  0.47 and 3.64 (each d, C-2 and C-7), 35.18 (d, C-1,3), 47.40 (d, C-3a,6c), 50.55 (q, OCH<sub>3</sub>), 54.09 (s, C-3b), 171.24 (s, C=O). Anal. Calcd for C<sub>18</sub>H<sub>18</sub>O<sub>4</sub>: C, 72.47; H, 6.08. Found: C, 72.16; H, 6.15.

**12:** IR (KBr, cm<sup>-1</sup>) 2945, 1712 (vs), 1643, 1440, 1252 (vs), 1142, 1123, 1092, 1038, 1015, 770, 750, 725; MS *m/z* (relative intensity) 298 (1%, M<sup>+</sup>), 207 (38), 180 (25), 179 (100), 178 (82), 177 (20), 165 (33),

152 (24), 149 (24), 115 (35), 103 (34), 91 (32), 77 (28), 59 (37); <sup>1</sup>H NMR (CDCl<sub>3</sub>)  $\delta$  1.79 (dt, *J*<sub>6,7</sub> = 3.5, *J*<sub>7,12</sub> = 10.9 Hz, 7-H), 2.02 (dt, *J*<sub>1,2</sub> = 1.8, *J*<sub>2,11</sub> = 8.8 Hz, 2-H), 2.17 (≈t, 1,3-H), 2.47 (dtt, *J*<sub>5,12</sub> = 1.2, *J*<sub>6,12</sub> = 3.0 Hz, 12-H), 2.67 (dq, *J*<sub>1,11</sub> = *J*<sub>3a,11</sub> = 1.4 Hz, 11-H), 2.99 (m, 6,8-H), 3.61 (s, OCH<sub>3</sub>), 3.73 (br s, 10a-H), 6.93 (br s, 5,9-H). NOE difference <sup>1</sup>H NMR spectroscopy<sup>46</sup> gave the following effects: saturation at  $\delta$  1.79 (7-H), enhancement at 2.47 (medium, 12-H) and 2.99 (strong, 6,8-H); saturation at 2.02 (2-H), enhancement at 2.17 (s, 1,3-H) and 2.67 (m, 11-H); saturation at 2.47 (12-H), enhancement at 1.79 (m, 7-H), 2.67 (m, 11-H), and 2.99 (s, 6,8-H); saturation at 2.67 (11-H), enhancement at 2.02 (m, 2-H), 2.17 (s, 1,3-H), and 2.47 (s, 12-H). The absorptions not mentioned did not show significant effects. <sup>13</sup>C NMR (CDCl<sub>3</sub>)  $\delta$  6.83 (d, 217 Hz, C-2), 12.40 (dt, 217, 10 Hz, C-11), 13.26 (d, 202 Hz, C-7), 17.53 (d, 200 Hz, C-12), 38.77 (dd, 167, 14 Hz, C-1,3), 46.32 (dm, 135 Hz, C-3a,10a), 47.96 (dd, 145, 15 Hz, C-6,8), 51.85 (q, 147 Hz, OCH<sub>3</sub>), 132.24 (s, C-4,10), 141.04 (d, 156 Hz, C-5,9), 169.95 (s, C=O). Anal. Calcd for C<sub>18</sub>H<sub>18</sub>O<sub>4</sub>: C, 72.47; H, 6.08. Found: C, 72.26; H, 5.86.

When the above reaction was conducted in the presence of piperylene, the ratio of **11** to **12** did not change. On resubmission to the irradiation in benzene, pure **11** and **12** proved to be stable.

The temperature dependence of the product ratio was investigated by irradiation (high-pressure mercury vapor lamp, Osram HBO 500 W/2, 500 W) of **3** in CD<sub>3</sub>CN in an NMR tube under nitrogen through a filter (Schott WG 345), which removed light of  $\lambda \leq 345$  nm. By means of NMR spectroscopy, the ratio of **11** to **12** was measured to be 1.0:2.3 (irradiation at 20 °C) and 1.0:3.6 (–47 °C).

**Dimethyl Octacyclo[7.5.0.0<sup>2,7</sup>.0<sup>3,5</sup>.0<sup>4,6</sup>.0<sup>8,14</sup>.0<sup>10,12</sup>.0<sup>11,13</sup>]tetradecane-1,8-dicarboxylate (13).** **A. Photolysis of Azo Compound 3.** A solution of **3** (500 mg, 1.53 mmol) in acetone (125 mL) was deoxygenated with a gentle stream of nitrogen for 15 min. The mixture was irradiated at 300 nm in a Rayonet reactor for 4 h at ambient temperature. The solvent was removed in vacuo, and the solid residue was dissolved in ether and precipitated with hexane to give **13** (181 mg, 40%) as a colorless powder, mp 141–143 °C: IR (KBr, cm<sup>-1</sup>) 3030, 2960, 2947, 2928, 1724 (vs), 1446, 1284, 1239, 1196, 1088, 1062, 765, 755, 735; MS *m/z* (relative intensity) 298 (5%, M<sup>+</sup>), 239 (27), 207 (42), 180 (31), 179 (100), 178 (69), 177 (17), 165 (35), 161 (20), 152 (18), 149 (16), 115 (21), 91 (19), 89 (17), 77 (19), 59 (23). <sup>1</sup>H NMR (C<sub>6</sub>D<sub>6</sub>):  $\delta$  1.55 (dt, *J*<sub>3,4</sub> = 1.6, *J*<sub>4,5</sub> = 8.9 Hz, 4-H), 1.83 (br t, 3,6-H), 1.87 (t, *J*<sub>10,11</sub> = *J*<sub>11,13</sub> = 2.2 Hz, 11,12-H), 1.93 (dtt, *J*<sub>2,5</sub> = 1.2, *J*<sub>3,5</sub> = 1.6 Hz, 5-H), 2.13 (ddt, *J*<sub>9,10</sub> = 5.8, *J*<sub>10,13</sub> = 6.2 Hz, 10-H), 2.25 (tt, *J*<sub>13,14</sub> = 6.2 Hz, 13-H), 2.39 (br s, 2,7-H), 2.62 (dd, *J*<sub>9,14</sub> = 8.1 Hz, 9-H), 3.53 (s, OCH<sub>3</sub>), 3.64 (dd, 14-H); <sup>13</sup>C NMR (CDCl<sub>3</sub>)  $\delta$  2.92 (dd, 215, 3 Hz, C-4), 5.34 (dtd, 215, 8, 3 Hz, C-5), 9.62 (d, 210 Hz, C-11,12), 32.02 (dd, 166, 13 Hz, C-3,6), 34.12 and 34.48 (each dd, 164, 10 Hz, C-10 and C-13), 40.49 (dm, 152 Hz, C-9), 49.95 (dm, 142 Hz, C-2,7), 51.44 (q, 147 Hz, OCH<sub>3</sub>), 56.85 (dm, 151 Hz, C-14), 62.27 (s, C-1,8), 174.32 (s, C=O). Anal. Calcd for C<sub>18</sub>H<sub>18</sub>O<sub>4</sub>: C, 72.47; H, 6.08. Found: C, 72.68; H, 6.02.

When the above reaction with 100 mg of **3** was interrupted after 15 min, the <sup>1</sup>H NMR spectrum of the crude product revealed the presence of diolefin **12** and the ratio **12**:**13** = 1:2.

When azo compound **3** was irradiated in benzene solution in the presence of benzophenone as triplet sensitizer, product **13** was also formed, but it was difficult to separate from benzophenone.

**B. Photolysis of Diolefin 12.** Photolysis of **12** (1.00 g, 3.35 mmol) in acetone (125 mL) for 3 h and workup as indicated in procedure A afforded product **13** (820 mg, 82%). In contrast, submission of the saturated compound **11** to these conditions left it unchanged.

**Dimethyl (1 $\alpha$ ,1 $\beta$ ,1 $\beta$ ,1 $\beta$ ,1 $\beta$ ,3 $\alpha$ ,4 $\alpha$ ,6 $\alpha$ ,6 $\beta$ ,6 $\beta$ )-1,1a,1b,1c,3a,4,6a,6b-Octahydro-1,4-ethenocyclobuta[*c*]cyclopropa[3,4]cyclobuta[1,2-*a*]cycloheptene-5,7-dicarboxylate (20).** In a sealed tube bis(bicyclobutane) **12** (700 mg, 2.35 mmol), dissolved in dry benzene (10 mL), was heated at 90 °C for 2 h. Evaporation of the solvent in vacuo and distillation of the residual oil at 150–155 °C (bath) (0.001 Torr) gave 540 mg (77%) of pure **20** as a colorless oil, which solidified rapidly to afford crystals with mp 88–90 °C (from acetone): IR (KBr, cm<sup>-1</sup>) 3040, 2950, 2910, 1710 (vs), 1650, 1440, 1250 (br, vs), 1170, 1150, 1050, 1030, 810, 760; MS *m/z* (relative intensity) 298 (2%, M<sup>+</sup>), 207 (38), 180 (27), 179 (100), 178 (81), 165 (37), 152 (30), 115 (43), 104 (22), 103 (33), 91 (31), 77 (28), 59 (42); <sup>1</sup>H NMR and <sup>13</sup>C NMR (see Tables I and II). NOE difference <sup>1</sup>H NMR spectroscopy<sup>46</sup> afforded the following effects: saturation at  $\delta$  7.40 (8-H), enhancement at 5.74 (weak, 3-H) and 4.38 (strong, 4-H); saturation at 5.74 (3-H), enhancement at 7.40 (w, 8-H), 6.07 (medium, 2-H), 4.38 (w, 4-H), and 2.98 (m, 3a-H); saturation at 4.38 (4-H), enhancement at 7.40 (s, 8-H), 5.74 (w, 3-H), and 2.98 (m, 3a-H); saturation at 2.02 (1a-H), enhancement at 6.07 (w, 2-H), 2.71

(44) Katz, T. J.; Wang, E. J.; Acton, N. *J. Am. Chem. Soc.* **1971**, *93*, 3782. Katz, T. J.; Roth, R. J.; Acton, N.; Carnahan, E. *J. Org. Synth.* **1973**, *53*, 157. We used methyl lithium containing no bromide, from CHEMETALL.

(45) Sauer, J.; Mielert, A.; Lang, D.; Peter, D. *Chem. Ber.* **1965**, *98*, 1435. Boger, D. L.; Coleman, R. S.; Panek, J. S.; Huber, F. X.; Sauer, J. *J. Org. Chem.* **1985**, *50*, 5377.

(46) Neuhaus, D. *J. Magn. Reson.* **1983**, *53*, 109. Kinns, M.; Sanders, J. K. M. *J. Magn. Reson.* **1984**, *56*, 518.



(m, 1b-H), 2.53 (s, 1-H), and 1.73 (m, 6b-H). The absorptions not mentioned did not show any effect. Anal. Calcd for  $C_{18}H_{18}O_4$ : C, 72.47; H, 6.08. Found: C, 72.51; H, 6.11.

When the above rearrangement was carried out in  $C_6D_6$  in an NMR tube, which contained mesitylene as internal standard, the yield of **20** was determined to be 94% on the basis of the integrals in the  $^1H$  NMR spectrum.

**Dimethyl (1 $\alpha$ ,3 $\alpha$ ,3 $\beta$ ,6 $\alpha$ ,7 $\beta$ ,8 $\alpha$ ,10 $\alpha\beta$ )-1,2,3,3a,6,7,8,10a-Octahydro-7-(phenylthio)-1,3,6,8-ethanediyliidencyclopentacyclononene-4,10-dicarboxylate (30).** A solution of bis(bicyclobutane) **12** (400 mg, 1.34 mmol) and thiophenol (206 mg, 1.87 mmol) in benzene (10 mL) was left at ambient temperature for 20 h. Thereafter, the mixture was extracted with 2 N aqueous NaOH and then with water. The benzene layer was dried ( $Na_2SO_4$ ), and the solvent was evaporated in vacuo. The solid residue was recrystallized from chloroform/hexane to give colorless **30** (514 mg, 94%), mp 130–132 °C: IR (KBr,  $cm^{-1}$ ) 2995, 2980, 2965, 2938, 2902, 2890, 1710 (vs), 1648, 1480, 1442, 1428, 1302, 1248 (vs), 1200, 1164, 1072, 1018, 787, 768, 757, 695; MS  $m/z$  (relative intensity) 408 (9%,  $M^+$ ), 267 (12), 259 (15), 239 (10), 227 (19), 207 (10), 199 (11), 179 (18), 178 (10), 165 (13), 150 (11), 149 (100), 91 (24), 83 (10), 77 (10), 59 (13);  $^1H$  NMR ( $CDCl_3$ )  $\delta$  1.03 (d,  $J_{2,2} = 7.0$  Hz, 2-H $\beta$ ), 1.36 (dt,  $J_{1,2\alpha} = 2.8$  Hz, 2-H $\alpha$ ), 2.33 (br d,  $J_{11,12} = 11.0$  Hz, 11-H), 2.66 (t,  $J_{1,11} = 2.8$  Hz, 1,3-H), 2.88 (dt,  $J_{6,12} = 8.2$  Hz, 12-H), 3.37 (t of AA' part of an AA'XX' spectrum, 6,8-H), 3.73 (s,  $OCH_3$ ), 3.96 (br s, 3a,10a-H), 4.24 (t,  $J_{6,7} = 7.7$  Hz, 7-H), 7.04 (XX' part of an AA'XX' spectrum = apparent d, line distance 2.8 Hz, 5,9-H), 7.17 (p-H), 7.24–7.32 (o-H, m-H);  $^{13}C$  NMR ( $CDCl_3$ )  $\delta$  36.19 (d, C-12), 38.89 (t, C-2), 43.98 (d, C-3a,10a), 45.15 (d, C-6,8), 45.46 (d, C-11), 47.83 (d, C-1,3), 51.99 (q,  $OCH_3$ ), 54.56 (d, C-7), 132.79 (s, C-4,10), 142.37 (d, C-5,9), 168.43 (s, C=O), 126.05 (p-C), 129.05 and 129.11 (o- and m-C), 137.05 (ipso-C). The assignment was established by means of 2D  $^{13}C$ ,  $^1H$  correlation. Anal. Calcd for  $C_{24}H_{24}O_4S$ : C, 70.56; H, 5.92. Found: C, 70.28; H, 6.06.

**Dimethyl (1 $\alpha$ ,2 $\beta$ ,3 $\alpha$ ,3 $\beta$ ,6 $\alpha$ ,8 $\alpha$ ,10 $\alpha\beta$ )-1,2,3,3a,6,7,8,10a-Octahydro-2-(phenylthio)-1,3,6,8-ethanediyliidencyclopentacyclononene-4,10-dicarboxylate (31).** Thioether **30** (87 mg, 0.21 mmol) was dissolved in  $C_6D_6$  (0.7 mL) and the resultant mixture heated at 80 °C in a sealed NMR tube. The progress of the reaction was monitored by means of  $^1H$  NMR spectroscopy. After 2 h, starting material **30** and the product thioether **31** were present in the ratio 1:6, which remained unchanged on continued heating. The 400-MHz  $^1H$  NMR spectrum did not show any side product. The isolation of pure **31** was achieved by chromatography (Chromatotron,  $SiO_2$ , hexane/ethyl acetate 2:1; several repetitions with the best fraction each time); 21 mg (24%) of colorless needles, mp 148–149 °C: IR (KBr,  $cm^{-1}$ ) 2995, 2980, 2938, 2899, 2882, 1710 (vs), 1643, 1473, 1439, 1425, 1297, 1246 (vs), 1198, 1160, 1070, 787, 768, 757, 698; MS  $m/z$  (relative intensity) 408 (11%,  $M^+$ ), 267 (11), 259 (14), 227 (17), 199 (10), 179 (18), 178 (11), 165 (13), 150 (11), 149 (100), 115 (11), 109 (10), 91 (28), 77 (14), 59 (20);  $^1H$  NMR ( $CDCl_3$ )  $\delta$  1.59 (dt,  $J_{6,7\beta} = 1.7$  Hz,  $J_{7,7} = 10.7$  Hz, 7-H $\beta$ ), 2.21 (dt,  $J_{1,11} = 2.9$  Hz,  $J_{3a,11} = 1.4$  Hz,  $J_{11,12} = 10.8$  Hz, 11-H), 2.55 (dt,  $J_{6,7\alpha} = 8.4$  Hz, 7-H $\alpha$ ), 2.74 (≈t, 1,3-H), 2.95 (dt,  $J_{6,12} = 8.1$  Hz, 12-H), 3.02 (td of AA' part of an AA'XX' spectrum, 6,8-H), 3.03 (t,  $J_{1,2} = 2.5$  Hz, 2-H), 3.70 (s,  $OCH_3$ ), 4.13 (br s, 3a,10a-H), 7.00 (XX' part of an AA'XX' spectrum = apparent d, line distance 2.8 Hz, 5,9-H), 7.16 (p-H), 7.26 (m-H), 7.32 (o-H);  $^{13}C$  NMR ( $CDCl_3$ ):  $\delta$  35.66 (d, C-12), 37.76 (t, C-7), 39.82 (d, C-6,8), 40.98 (d, C-3a,10a), 44.23 (d, C-11), 50.80 (d, C-1,3), 51.95 (q,  $OCH_3$ ), 52.23 (d, C-2), 129.64 (s, C-4,10), 145.89 (d, C-5,9), 168.92 (s, C=O), 126.09 (p-C), 128.88 (m-C), 129.90 (o-C), 136.58 (ipso-C). The assignment was established by means of 2D  $^{13}C$ ,  $^1H$  correlation. Anal.

Calcd for  $C_{24}H_{24}O_4S$ : C, 70.56; H, 5.92. Found: 69.79; H, 5.96.

**Dimethyl (1 $\alpha$ ,1 $\alpha\beta$ ,2 $\alpha$ ,2 $\alpha\beta$ ,5 $\alpha$ ,6 $\beta$ ,7 $\alpha$ ,9 $\alpha\beta$ ,9 $\beta\beta$ )-Dibromo-1a,2,2a,5,6,7,9a,9b-octahydro-1,5,7-metheno-1H-cyclopropa[3,4]cyclopenta[1,2]cyclononene-3,9-dicarboxylate (38).** To a stirred solution of bis(bicyclobutane) **12** (100 mg, 0.34 mmol) in 15 mL of anhydrous  $CCl_4$  was added a solution of bromine (59 mg, 0.37 mmol) in 10 mL of  $CCl_4$  at ambient temperature in a manner that each drop of the reagent was decolorized prior to the addition of the next one (altogether 20 min). Thereafter, the mixture was stirred for 2 h, extracted with a saturated solution of  $Na_2S_2O_3$ , and dried over  $K_2CO_3$ . The solvent was evaporated in vacuo, and the residual oil yielded a brown solid on treatment with ether. Recrystallization from ether gave colorless **38** (60 mg, 39%), mp 153–156 °C: IR (KBr,  $cm^{-1}$ ) 2938, 2910, 1695 (vs), 1648, 1430, 1408, 1368, 1240 (vs), 1196, 777; MS  $m/z$  (relative intensity) 347 (21%), 345 (21), 265 (27), 238 (21), 237 (34), 206 (22), 205 (33), 179 (74), 178 (100), 177 (35), 165 (29), 152 (28), 149 (27), 115 (28), 103 (21), 91 (24), 77 (28), 59 (47);  $^1H$  NMR ( $CDCl_3$ )  $\delta$  1.46 (≈q, 1-H), 1.89 (dt,  $J_{1,9b} = 8.6$ ,  $J_{1a,9b} = 6.0$ ,  $J_{9a,9b} = 6.2$  Hz, 9b-H), 2.00 (ddd,  $J_{1,1a} = 8.8$ ,  $J_{1a,2} = 5.2$  Hz, 1a-H), 3.30 (dtd,  $J_{1,10} = 9.7$ ,  $J_{5,10} = J_{7,10} = 7.7$ ,  $J_{8,10} = 1.2$  Hz, 10-H), 3.58 (m, 5-H, 7-H), 3.68 and 3.71 (each s, 2  $OCH_3$ ), 4.23 (dd,  $J_{2a,9a} = 11.5$  Hz, 9a-H), 4.70 (t, 2a-H), 4.78 (t,  $J_{5,6} = J_{6,7} = 7.4$  Hz, 6-H), 5.36 (dd,  $J_{2,2a} = 11.0$  Hz, 2-H), 6.96 (apparent br d, line distance ca. 3 Hz, probably 8-H), 7.32 (apparent d, line distance 3.3 Hz, probably 4-H);  $^{13}C$  NMR ( $CDCl_3$ ) 21.05 (d, 156 Hz, C-1), 27.24 and 32.54 (each d, 174, 172 Hz, C-1a and C-9b), 33.43 (d, 130 Hz, C-10), 41.53 and 41.70 (each d, 134, 136 Hz, C-2a and C-9a), 48.41 and 48.68 (each d, 144, 143 Hz, C-5 and C-7), 50.98 and 57.42 (each d, 157 Hz, C-2 and C-6), 52.09 and 52.35 (each q, 147, 2  $OCH_3$ ), 129.85 and 134.73 (each s, C-3 and C-9), 143.68 and 146.05 (each d, 158 Hz, C-4 and C-8), 167.77 (s, double intensity, 2 C=O). Anal. Calcd for  $C_{18}H_{18}Br_2O_4$ : C, 47.19; H, 3.96. Found: C, 46.89; H, 4.10.

**Acknowledgment.** This research has been supported by the Fonds der Chemischen Industrie and the Deutsche Forschungsgemeinschaft. In particular, S.F. (1981–1982) and A.K. (1987–1988) thank the Stiftung Stipendien-Fonds des Verbandes der Chemischen Industrie e.V. for fellowships. We are also grateful to the Union Rheinische Braunkohlen Kraftstoff AG for gifts of dimethyl ether.

**Registry No.** 3, 65364-44-5; 3-*d*<sub>4</sub>, 113627-77-3; 4, 659-85-8; 4-*d*<sub>2</sub>, 87986-01-4; 5, 2166-14-5; 7, 113627-78-4; 8, 113646-60-9; 9, 113627-79-5; 10, 113627-80-8; 11, 113627-81-9; 12, 113627-82-0; 12-*d*<sub>4</sub>, 113627-91-1; 13, 113627-83-1; 20, 113627-84-2; 20-*d*<sub>4</sub>, 113627-89-7; 21, 113627-88-6; 28, 113646-61-0; 29, 113627-90-0; 30, 113627-85-3; 31, 113627-86-4; 38, 113627-87-5;  $C_6H_5SH$ , 108-98-5; norbornene, 498-66-8; norbornadiene, 121-46-0.

**Supplementary Material Available:** General methods of the Experimental Section, spectral and analytical data of 7–10, experimental details for the preparation of 12-*d*<sub>4</sub>, 20-*d*<sub>4</sub>, 21, 28, and 29 as well as spectral and analytical data of these compounds, X-ray collection, structure determination, and refinement for 21, and bond distances and angles (Table III), atomic coordinates and averaged thermal parameters (Table IV) for C and O atoms, anisotropic thermal parameters of C and O atoms (Table V), and atomic coordinates and isotropic thermal parameters of the H atoms (Table VI) of 21 (12 pages). Ordering information is given on any current masthead page.